

Q.TÀ SCATOLA PACKAGE Q.TY	50
PESO SCATOLA PACKAGE WEIGHT	6 kg 13.23 lbs
DIMENSIONI SCATOLA PACKAGE DIMENSION	38x12x15 8.66x13.78x8.66 inches

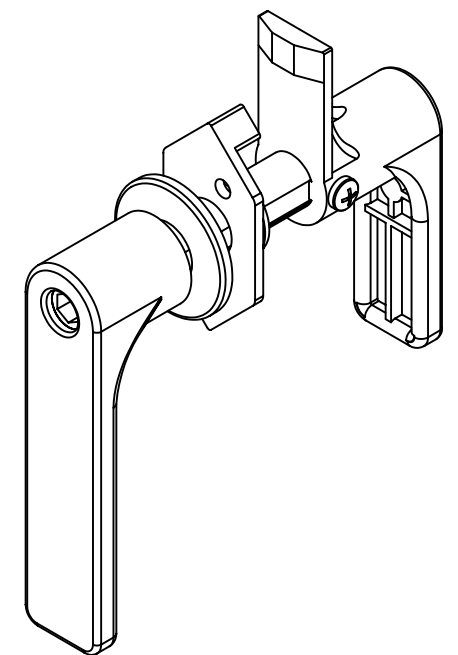
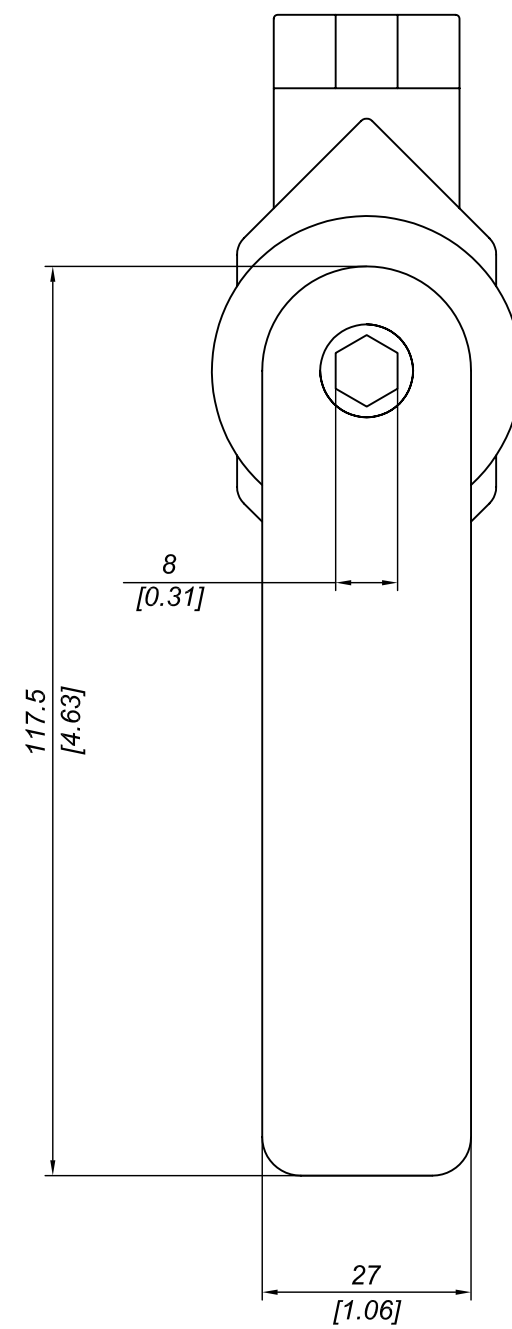
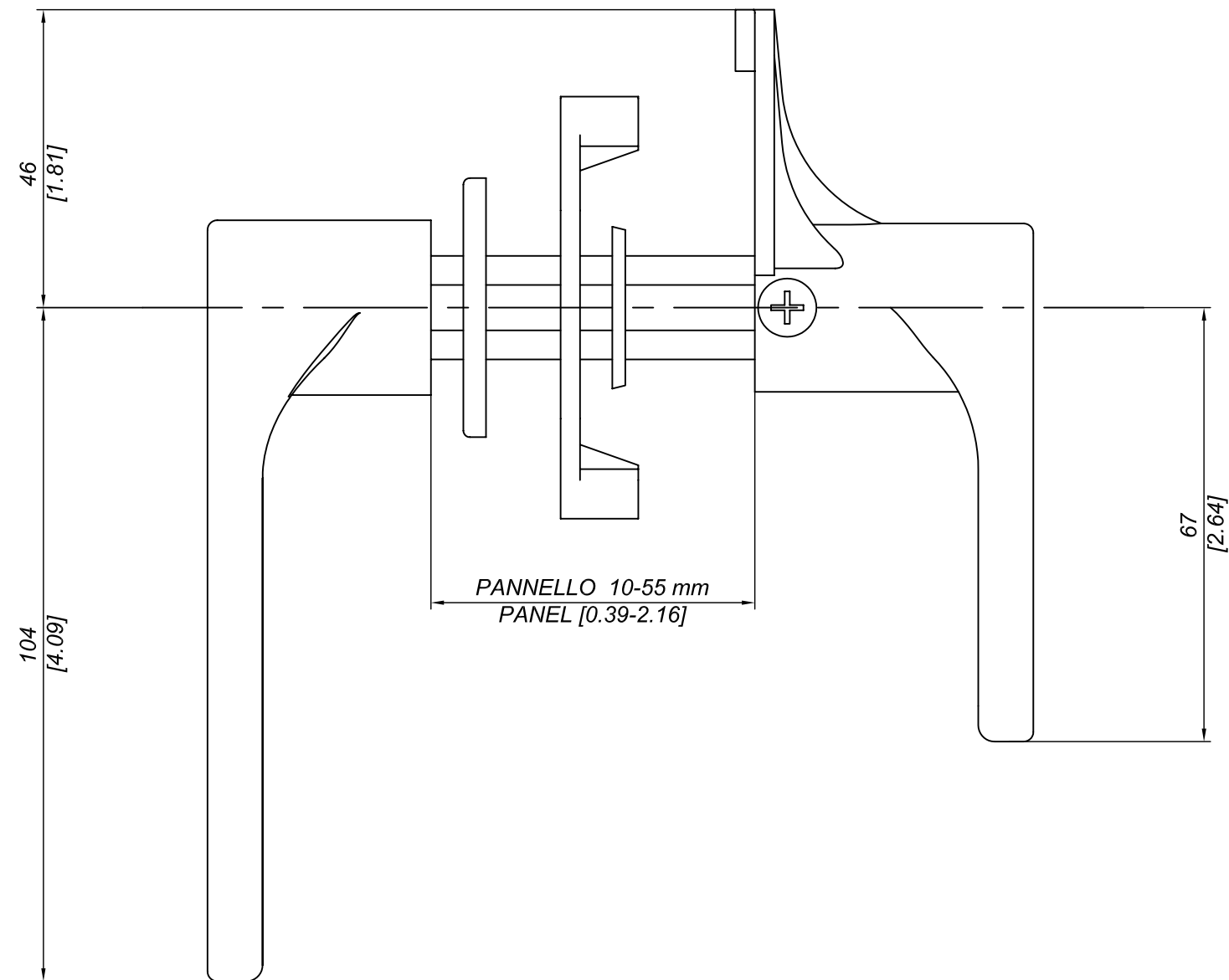

DESCRIZIONE MANIGLIA NYLON DOPPIA		PRO-LAM s.r.l. ALLUMINIO	
DESCRIPTION DOUBLE NYLON HANDLE			
MATERIALE MATERIAL	PA6+30%G.F.	TRATTAMENTO TREATMENT	--
PESO TEORICO THEORETICAL WEIGHT	-- kg -- lb	NORMA TOLLERANZA STANDARD TOLERANCE	--
		SCALA SCALE	1:1
		DATA DATE	2009/07/18
		CODICE CODE	AN70
		FORMATO SIZE	A3

Questo disegno è di proprietà riservata alla ditta PRO-LAM ALLUMINIO s.r.l. A termini di legge è assolutamente vietato riprodurre o comunicare a terzi il contenuto del presente disegno. This drawing is a property of PRO-LAM ALLUMINIO s.r.l. This drawing shall not be reproduced or released to others except as otherwise authorized by PRO-LAM ALLUMINIO s.r.l.