

|   |                                       |
|---|---------------------------------------|
| Q.TÀ SCATOLA<br>PACKAGE Q.TY            | 50                                    |
| PESO SCATOLA<br>PACKAGE WEIGHT          | 6 kg<br>13.23 lbs                     |
| DIMENSIONI SCATOLA<br>PACKAGE DIMENSION | 22x35x22 cm<br>8.66x13.78x8.66 inches |

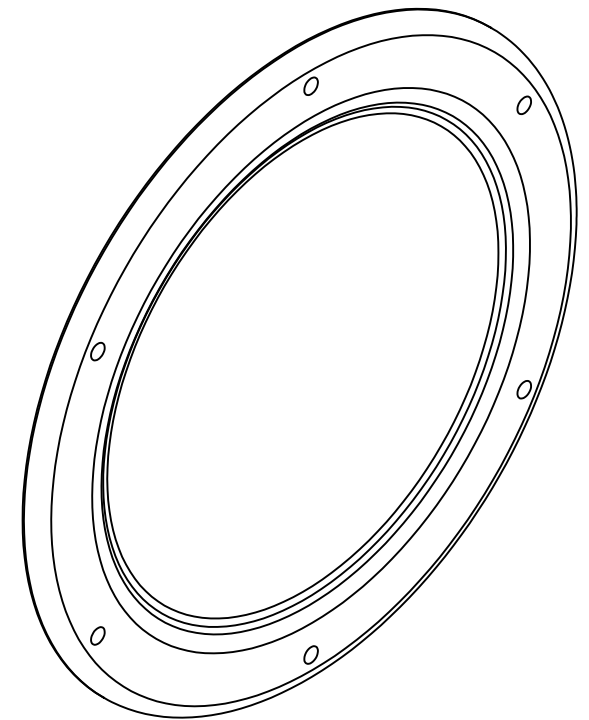
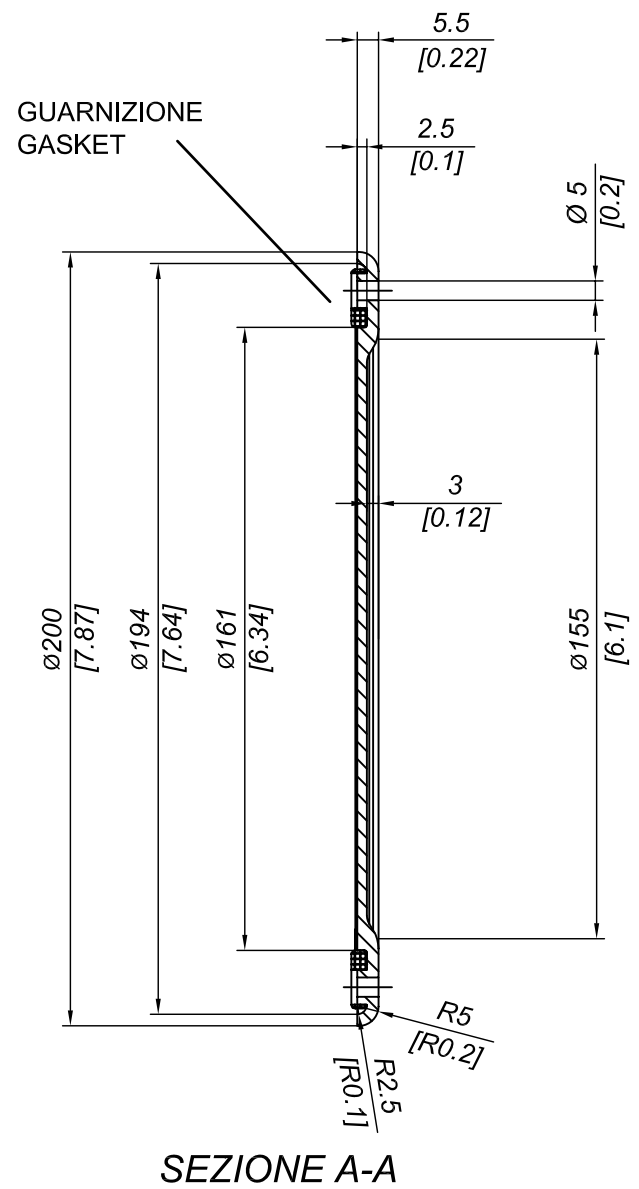
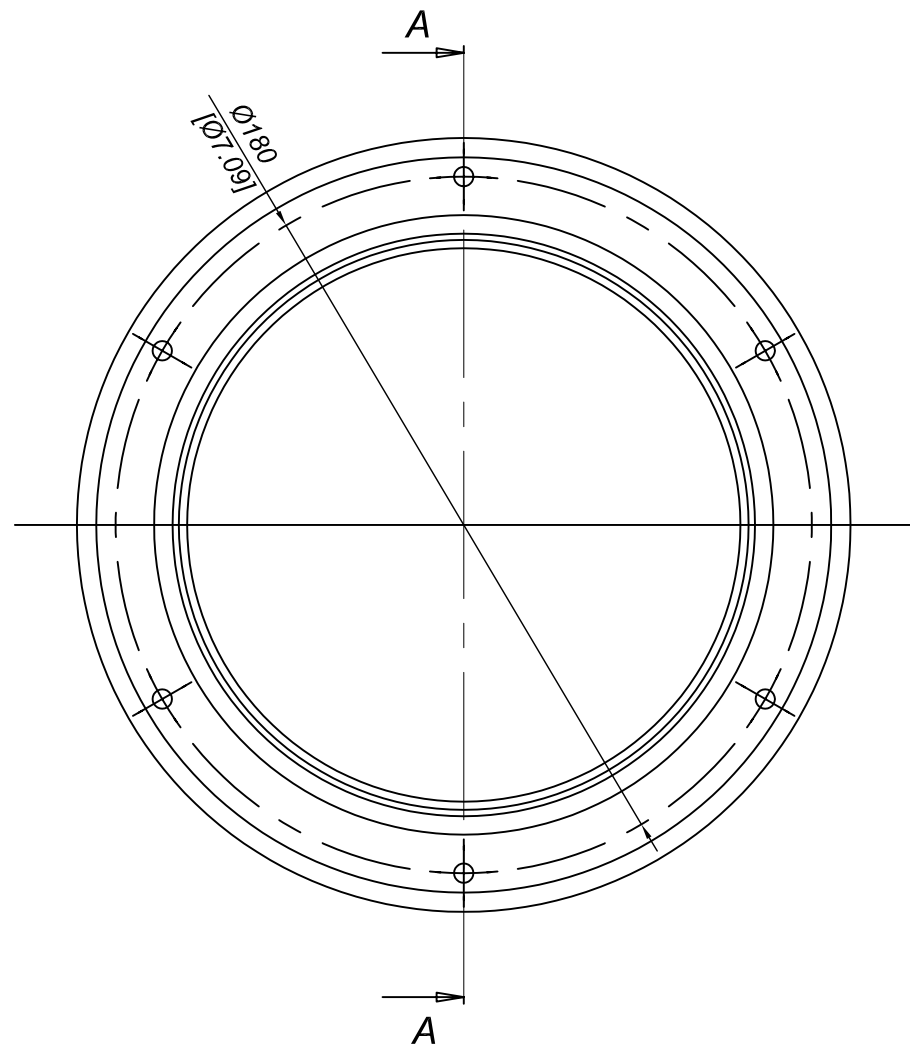

|                                     |                                |  |            |
|-------------------------------------|--------------------------------|--|------------|
| DESCRIZIONE<br><b>OBLO' PIANO</b>   |                                |  |            |
| DESCRIPTION<br><b>FLAT PORTHOLE</b> |                                |  |            |
| MATERIALE<br>MATERIAL               | POLICARBONATO<br>POLYCARBONATE | TRATTAMENTO<br>TREATMENT               | --         |
| PESO TEORICO<br>THEORETICAL WEIGHT  | -- kg<br>-- lb                 | NORMA TOLLERANZA<br>STANDARD TOLERANCE | --         |
| SCALA<br>SCALE                      | 1:2                            | DATA<br>DATE                           | 2009/07/18 |
| CODICE<br>CODE                      | N181                           | FORMATO<br>SIZE                        | A3         |

Questo disegno è di proprietà riservata alla ditta PRO-LAM ALLUMINIO s.r.l. A termini di legge è assolutamente vietato riprodurre o comunicare a terzi il contenuto del presente disegno. This drawing is a property of PRO-LAM ALLUMINIO s.r.l. This drawing shall not be reproduced or released to others except as otherwise authorized by PRO-LAM ALLUMINIO s.r.l.